



OMNI GEAR®

Rotary Cutter Gear Drives

Creating Value for our Customers  
[www.OmniGear.com](http://www.OmniGear.com)

# Physical Dimensions

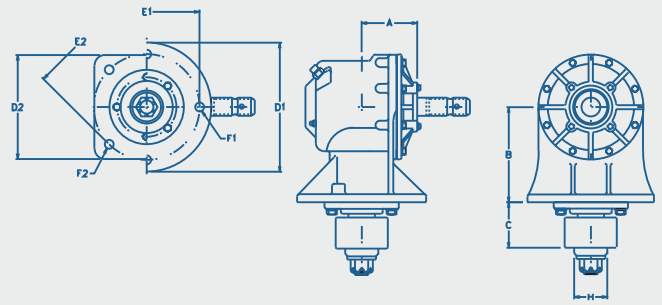

## Right Angle Drives

Model	Maximum Weight of Unit		CL to Thru Cap A		CL to Flange B		Flange to Hub Pilot C		Hub Pilot Diameter H		Flange Diameter D1		Bolt Hole Pattern E1		Mounting Holes F1		Flange Square Size D2		Bolt Hole Pattern E2		Mounting Holes F2	
	lb	kg	in	mm	in	mm	in	mm	in	mm	in	mm	in	mm	in	mm	in	mm	in	mm	in	mm
RC-20	34	15	3.0	76	6.5	165	2.40	61.0	-	-	-	-	-	-	-	-	6.18	157	6.8	171.5	(4) 0.67	(4) 17
RC-27	47	21	3.5	88	6.4	164	2.40	61.0	-	-	-	-	-	-	-	-	6.18	157	6.8	171.5	(4) 0.67	(4) 17
RC-30	51	23	3.9	100	6.4	164	3.30	84.0	2.5	63.5	-	-	-	-	-	-	6.89	175	6.8	171.5	(4) 0.67	(4) 17
RC-51	56	25	3.7	94	6.4	164	3.50	88.9	2.5	63.5	-	-	-	-	-	-	6.89	175	6.8	171.5	(4) 0.67	(4) 17
RC-61	81	37	4.2	107	7.2	183	3.50	88.9	2.5	63.5	9.5	242.0	8.0	203.2	(4) 0.787	(4) 20	-	-	-	-	-	-
RC-71	83	38	4.2	107	7.2	183	3.50	88.9	2.5	63.5	9.5	242.0	8.0	203.2	(4) 0.787	(4) 20	-	-	-	-	-	-
RC-81	98	45	4.6	116	11.0	279	3.50	88.9	2.5	63.5	9.6	245.0	8.0	203.2	(4) 0.787	(4) 20	-	-	-	-	-	-
RC-100	96	44	4.8	121	7.1	180	3.78	96.0	2.5	63.5	9.4	240.0	8.0	203.2	(4) 0.787	(4) 20	-	-	-	-	-	-
RC-130S	109	49	5.1	130	7.1	180	4.00	102.0	2.9	73.0	9.8	250.0	8.0	203.2	(6) 0.807	(6) 21	-	-	-	-	-	-
RC-130L	120	54	5.1	130	7.1	180	7.20	184.0	3.8	96.0	9.8	250.0	8.0	203.2	(6) 0.807	(6) 21	-	-	-	-	-	-
RC-145	110	50	5.6	142	8.9	225	8.05	204.5	3.8	96.0	10.2	260.0	8.0	203.2	(6) 0.807	(6) 21	-	-	-	-	-	-
RC-150L	145	66	5.1	130	11.0	280	7.20	184.0	3.8	96.0	9.8	250.0	8.0	203.2	(6) 0.807	(6) 21	-	-	-	-	-	-
RC-200	220	100	6.4	162	9.5	241	8.00	203.0	5.3	135.0	11.8	300.0	10	254.0	(6) 0.905	(6) 23	-	-	-	-	-	-

Custom shafts, oil ports and mounting hole positions available. Contact Omni Gear for details.

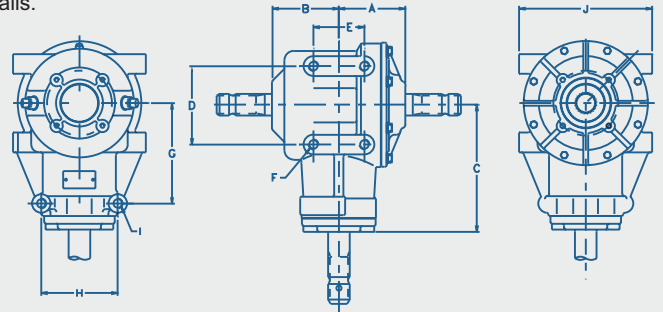

## Divider Drives- Side Mount 90°

Model	Maximum Weight of Unit		CL to Thru Cap A		CL to Hsg. end B		CL to Hsg. end C		Bolt Hole Pattern D		Bolt Hole Pattern E		Bolt Hole Pattern H		CL to Mtg. Holes G		Mounting Holes F		Mounting Holes I		Mounting Span J	
	lb	kg	in	mm	in	mm	in	mm	in	mm	in	mm	in	mm	in	mm					in	mm
RC-40T	45	20	3.9	100	2.8	71	7.5	191	4.5	113.0	2.75	69.9	4.75	120.7	5.75	146	(8) 5/8"-11UNC-2B		(8) 5/8"-11UNC-2B		6.0	152.4
RC-61T	70	32	4.2	107	4.3	108	8.0	204	5.0	127.0	3.25	82.6	4.88	123.8	6.40	162.7	(8) 5/8"-11UNC-2B		(2) 5/8"-11UNC-2B		8.0	203.2

Custom shafts, oil ports and mounting hole positions available. Contact Omni Gear for details.

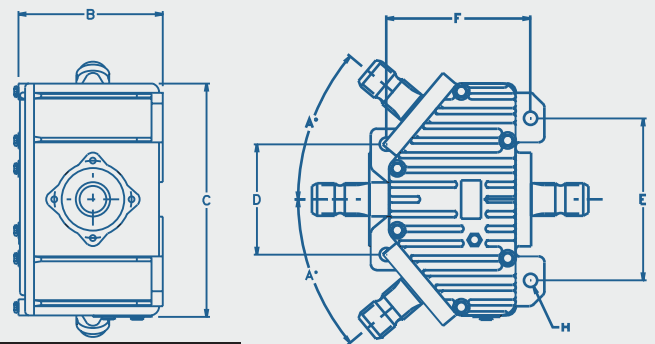

## Divider Drives 40°

Model	Maximum Weight of Unit		Shaft Angle A	Gearbox Height B		Gearbox Width C		Bolt Hole Pattern D		Bolt Hole Pattern E		Bolt Hole Pattern F		Mounting Holes H
	lb	kg		in	mm	in	mm	in	mm	in	mm	in	mm	
RCD-90	80	36	40	7.7	196	12.4	315	5.9	150	8.7	220	7.7	196	(4) 18mm thru
RCD-101	131	59	40	8.3	210	20.5	520	5.7	144	5.7	144	5.7	144	(4) 3/4"-10UNC-2B

Custom shafts, oil ports and mounting hole positions available. Contact Omni Gear for details.



# Physical Dimensions

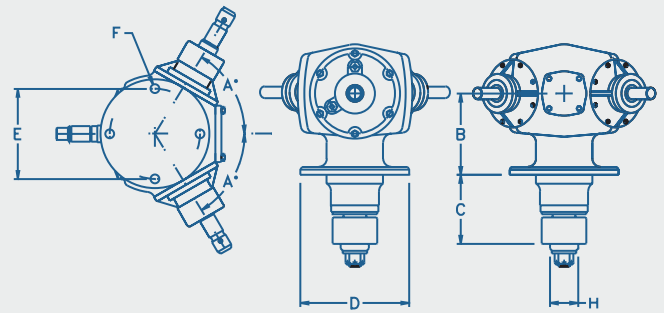

## Divider Drives-60°

Model	Maximum Weight of Unit		Shaft Angle A	CL to Flange B		Flange to Hub Pilot C		Hub Pilot Diameter H		Flange Diameter D		Bolt Hole Pattern E		Mounting Holes F	
	lb	kg		in	mm	in	mm	in	mm	in	mm	in	mm	in	mm
RC-110	140	64	60	7.2	183	6.1	156	2.5	64	9.6	245	8.0	203	(4) 0.787	(4) 20.0
RC-110Y	110	60	60	7.2	183	-	-	-	-	9.6	245	8.0	203	(4) 0.787	(4) 20.0

Custom shafts, oil ports and mounting hole positions available. Contact Omni Gear for details.

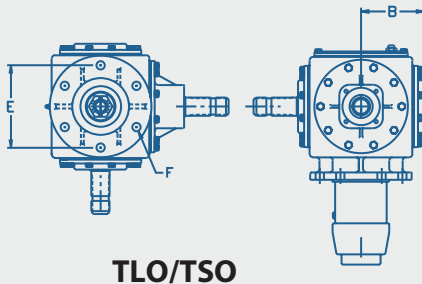

TLO/TSO

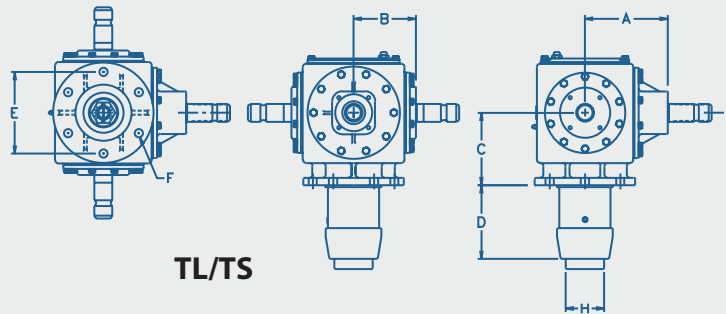

TL/TS

## Divider Drives- Base Mount 90°

Model	Maximum Weight of Unit		CL to Thru Cantilevered Cap A		CL to Thru Cap B		CL to Flange C		Flange to Hub Pilot D		Hub Pilot Diameter H		Bolt Hole Pattern E		Mounting Holes F	
	lb	kg	in	mm	in	mm	in	mm	in	mm	in	mm	in	mm	in	mm
RC-65TL	88	40	6.5	164	4.3	110	7.2	183	3.5	88.9	2.50	63.5	8.00	203.2	(4) 0.79	(4) 20.0
RC-65TLO	88	40	6.5	164	4.3	110	7.2	183	3.5	88.9	2.50	63.5	8.00	203.2	(4) 0.79	(4) 20.0
RC-91TL	200	91	4.6	116	7.5	191	10.9	278	3.5	88.9	2.50	63.5	8.00	203.2	(4) 0.79	(4) 20.0
RC-91TLO	200	91	4.6	116	7.5	191	10.9	278	3.5	88.9	2.50	63.5	8.00	203.2	(4) 0.79	(4) 20.0
RC-130T	125	57	8.1	206	6.1	155	7.1	180	-	-	-	-	8.00	203.2	(6) 0.807	(6) 20.5
RC-130TL	176	80	8.1	206	6.1	155	7.1	180	7.2	184.0	3.78	96.0	8.00	203.2	(6) 0.807	(6) 20.5
RC-130TLO	173	79	8.1	206	6.1	155	7.1	180	7.2	184.0	3.78	96.0	8.00	203.2	(6) 0.807	(6) 20.5
RC-130TS	165	75	8.1	206	6.1	155	7.1	180	4.0	102.0	2.87	73.0	8.00	203.2	(6) 0.807	(6) 20.5
RC-130TSO	162	74	8.1	206	6.1	155	7.1	180	4.0	102.0	2.87	73.0	8.00	203.2	(6) 0.807	(6) 20.5

Custom shafts, oil ports and mounting hole positions available. Contact Omni Gear for details.

# Configuration Options

## Right Angle Drives



## Divider Drives

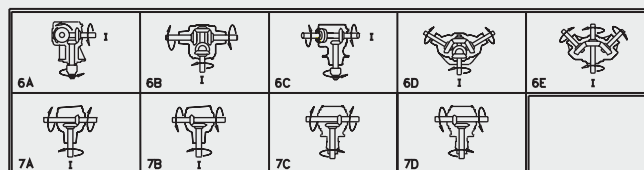

**Seals**

High quality triple-lip oil seals standard. Other options include Viton seals and cartridge type seals.

**Housing**

Ductile iron is standard.

**Spline Gearfit**

Splined gear to shaft connection is standard.

**Shaft Extensions**

Shaft extensions can be splined, keyed, or with pin holes. Multiple shaft extension units also available.

**End Caps**

Precision cast iron caps standard.

**Clutch**

Free wheel clutch optional.

**Pressure Relief Plug**

Pressure relief plug standard. Optional oil level available.

**Lubrication**

Units can be filled with mineral or synthetic oil/greases according to application requirements. Gearcase porting for oil flow to lower bearings standard.

**Gearing**

Forged blank, precision machine cut gearing is standard. Precision forged straight bevel, spiral bevel and lapped spiral bevel gearing also available.

**Coatings**

Red Oxide primer standard. Other coatings are available.

**Bearings**

Roller bearings standard in light duty units. ISO tapered bearings standard in larger units.

**Shafts**

Carburized alloy steel shafts standard.

**Blade Hubs**

Blade hubs available. Seal protector hubs also available.

**Labyrinths**

Output seal labyrinths available for extra seal protection.

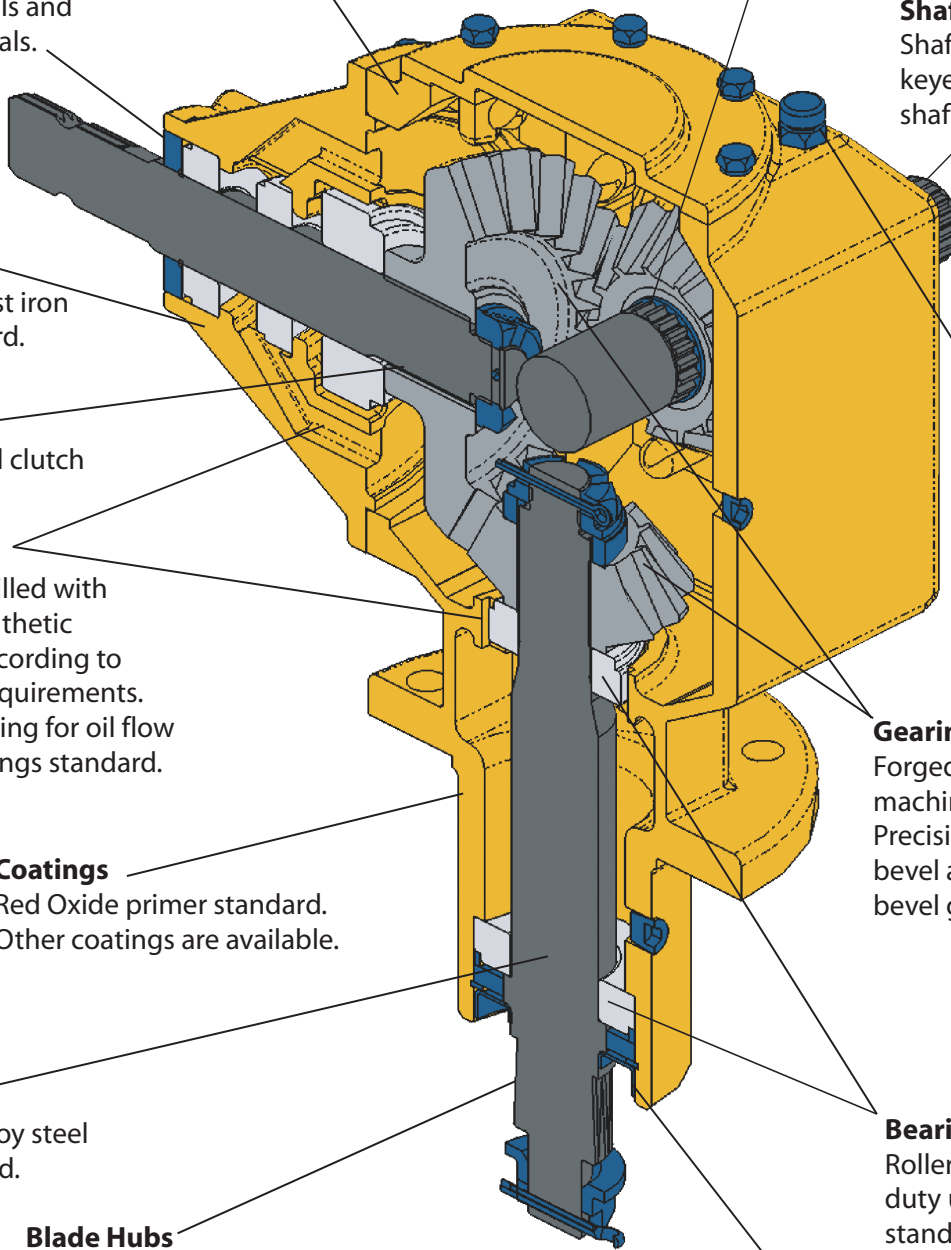

**OMNI GEAR®**



E-mail: [Sales@OmniGear.com](mailto:Sales@OmniGear.com) Web: [www.OmniGear.com](http://www.OmniGear.com)

©2003 Omni Gear®, All rights reserved